

1

2

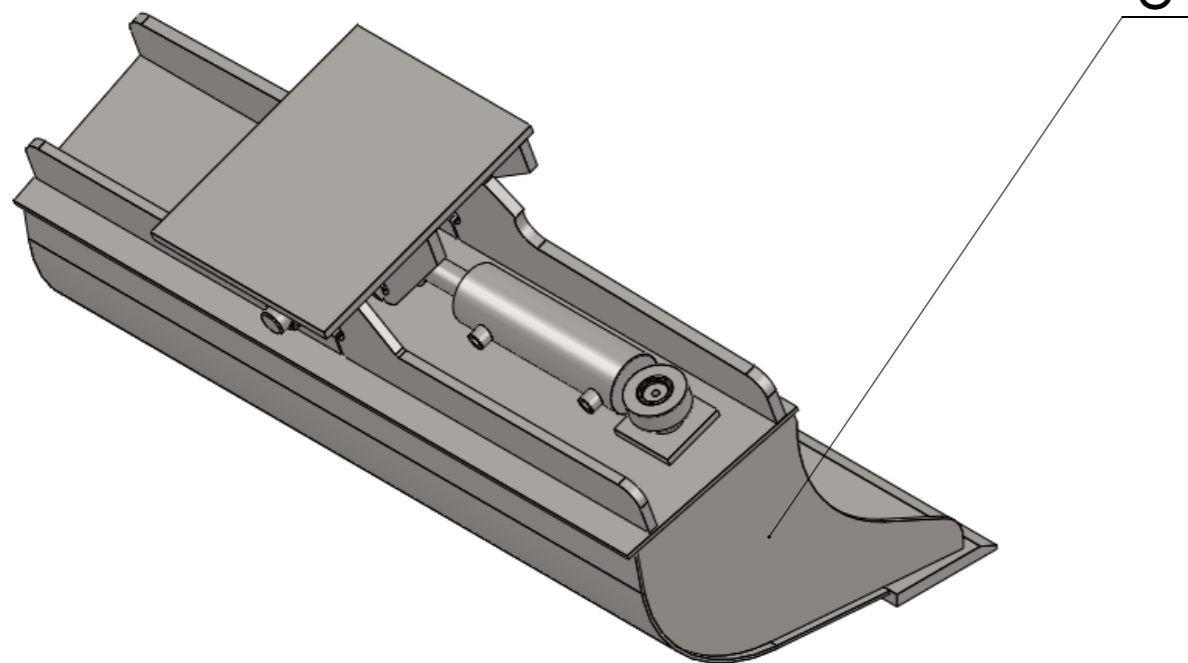

3

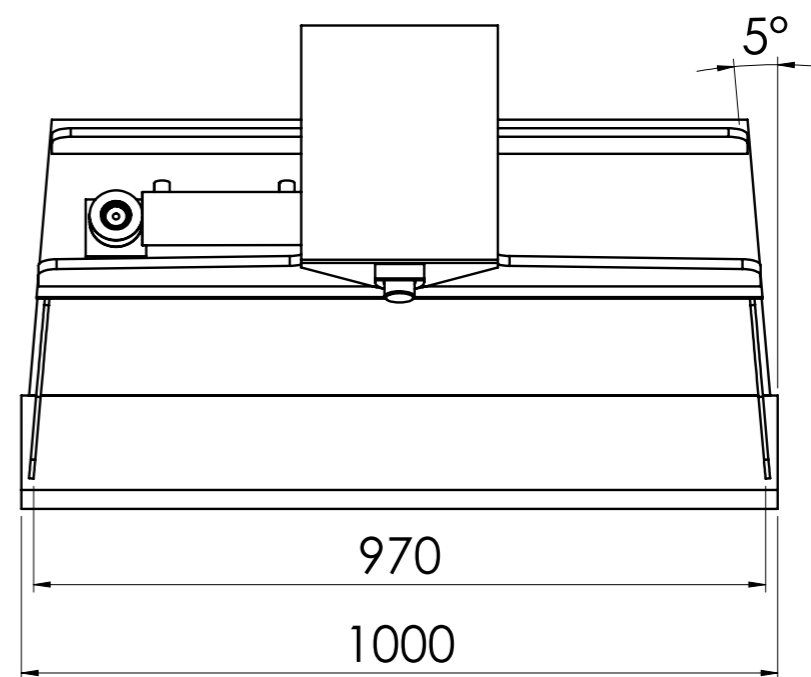
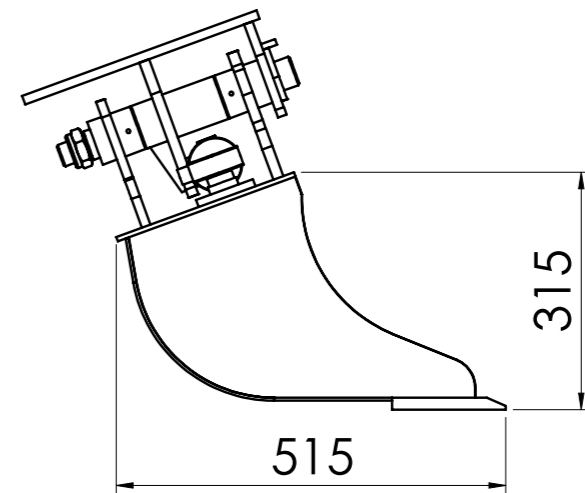

3	Side member	HB 400	6 mm
2	Bottom plate	HB 400	4 mm
1	Front edge	HB 500	16x150x1000 mm

NO.	TITLE	MATERIAL	DESCRIPTION
-----	-------	----------	-------------

	Volume	70 L	Mass	100 kg	Scale
--	--------	------	------	--------	-------

Drawn	Teet Toming	Name	
Checked		HPB104	
Approved			

	Sheet	Date
	1 of 1	27.05.2015

Recommended machine weight <2 t