

1

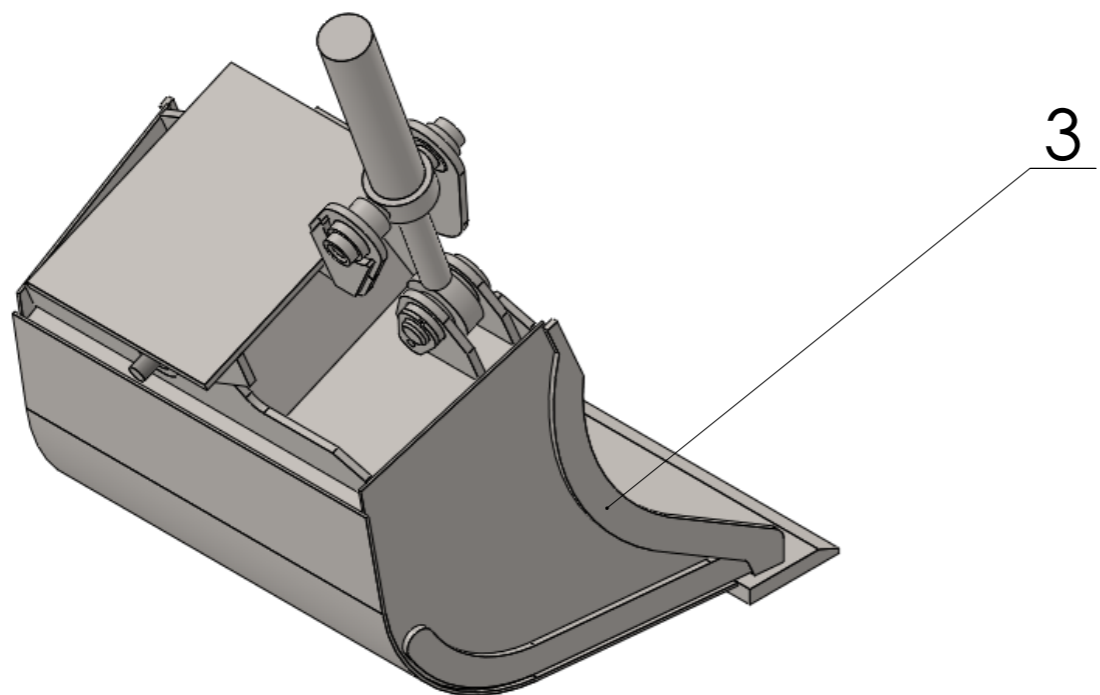

2

3

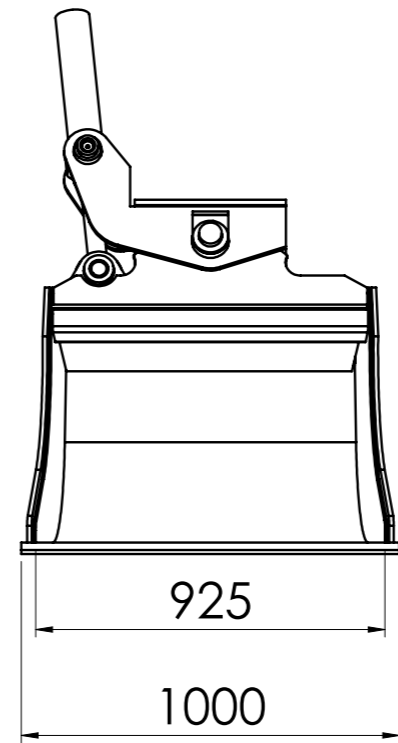

925

1000

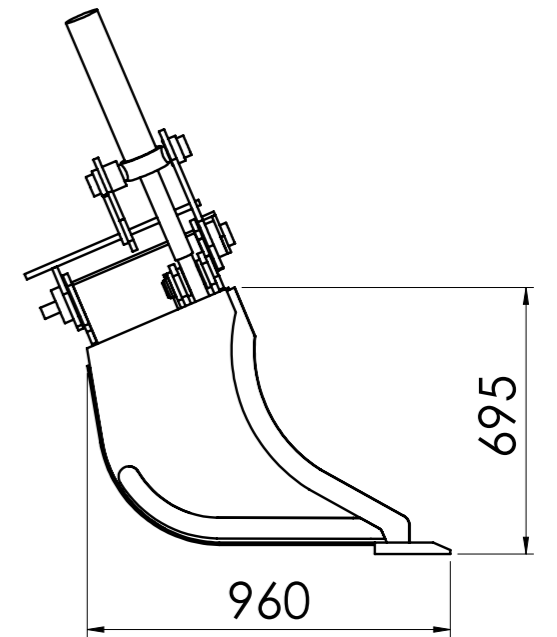

960

695

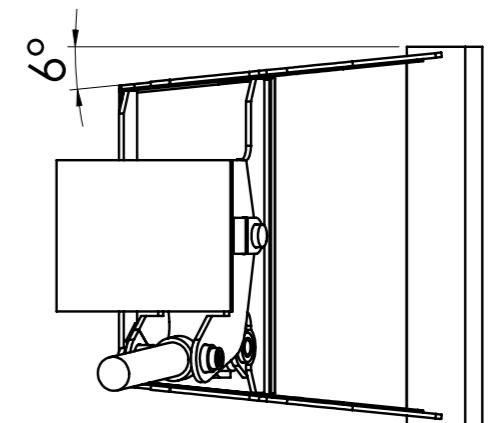

6°

Recommended machine weight <8 t

3	Side member	HB 400	12 mm
2	Bottom plate	HB 400	6 mm
1	Front edge	HB 500	20x200x1000 mm
NO.	TITLE	MATERIAL	DESCRIPTION

	Volume	300 L	Mass	300 kg	Scale
--	--------	-------	------	--------	-------

Drawn	Teet Toming	Name	
Checked		HPB113	
Approved			

	Sheet	Date
	1 of 1	2.06.2015