

1

2

3

4

5

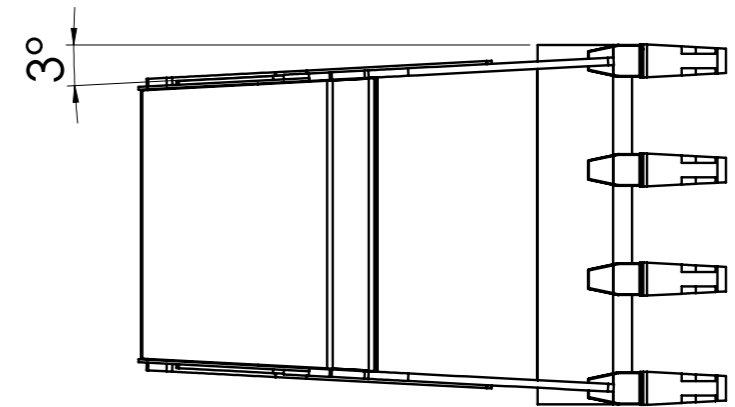
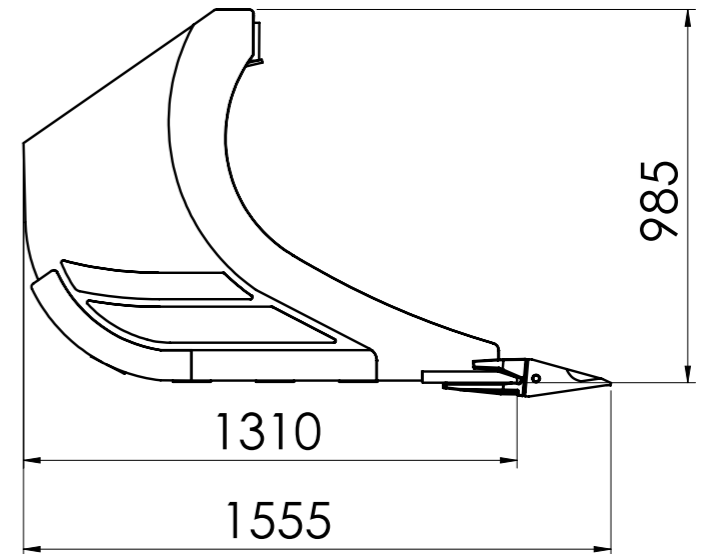
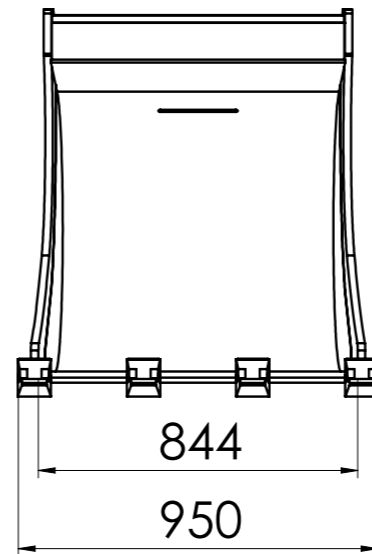
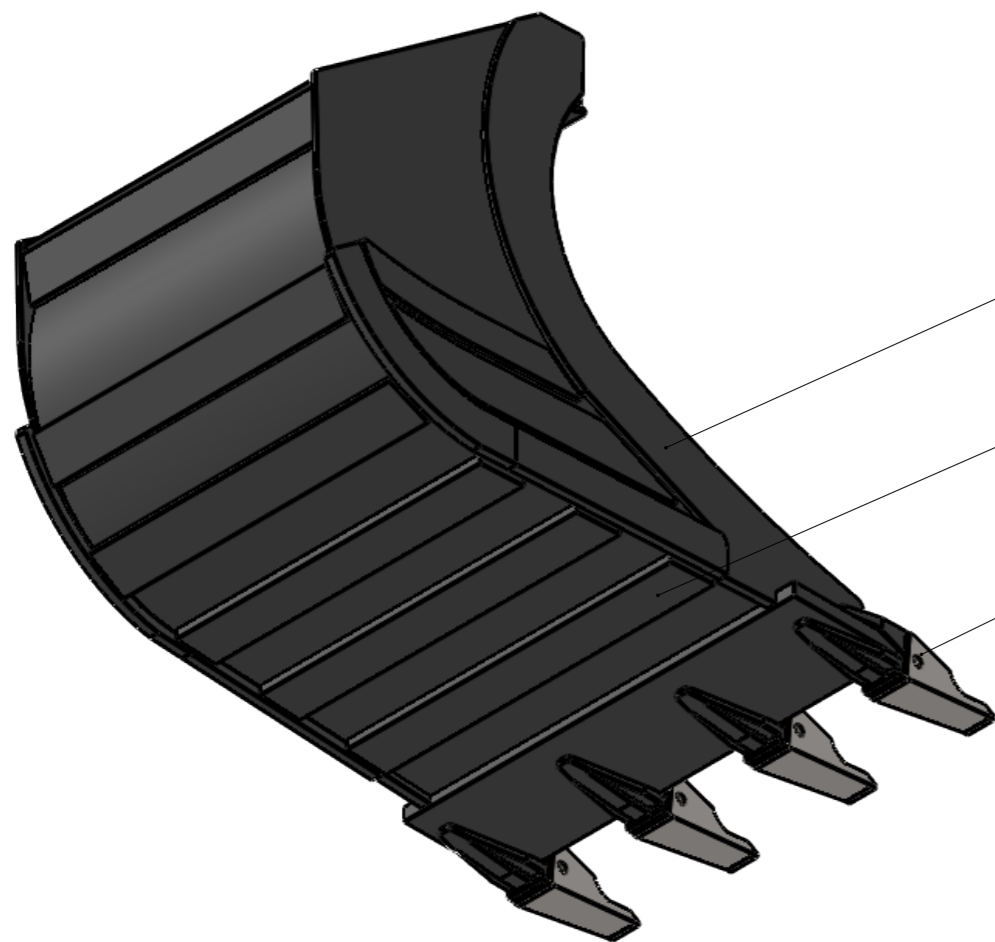

5	Teeth	-	J300
4	Bottom bar	HB 500	20x100 mm
3	Side member	HB 400	20 mm
2	Bottom plate	S355	8 mm
1	Front edge	HB 500	30x250x950 mm
NO.	TITLE	MATERIAL	DESCRIPTION

	Volume	850 L	Mass	585 kg	Scale
	Drawn	Teet Toming	Name	DGB-220	
	Checked				
Approved					
			Sheet	Date	
			1 of 1	5.04.2016	