

1

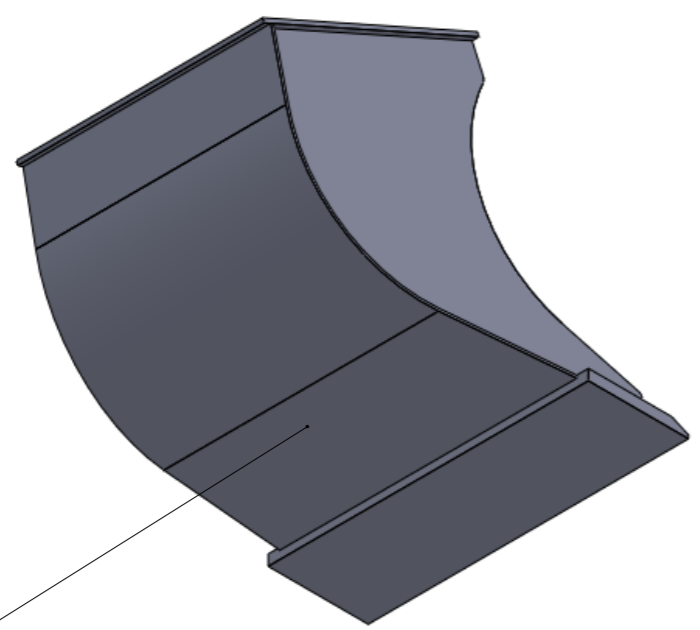

2

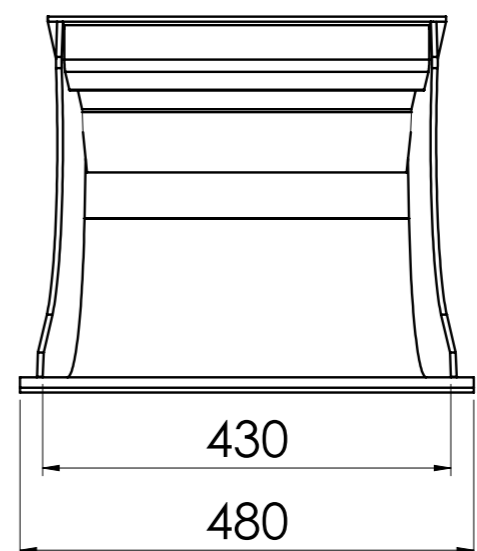
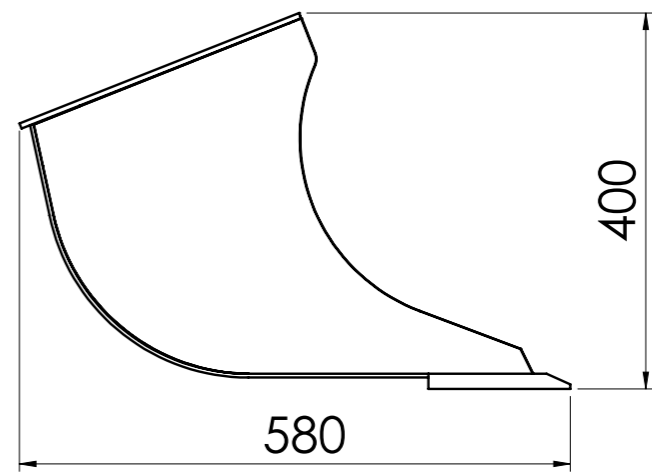

3	Side	S355	6 mm
2	Bottom plate	HB 400	4 mm
1	Front edge	HB 500	16x150x480 mm
NO.	TITLE	MATERIAL	DESCRIPTION

	Volume	55 L	Mass	40 kg	Scale

Drawn	Teet Toming	Name DGB241
Checked		
Approved		

	Sheet	Date
	1 of 1	29.04.2015

Recommended machine weight <1 t