

- 1
- 2
- 3
- 4

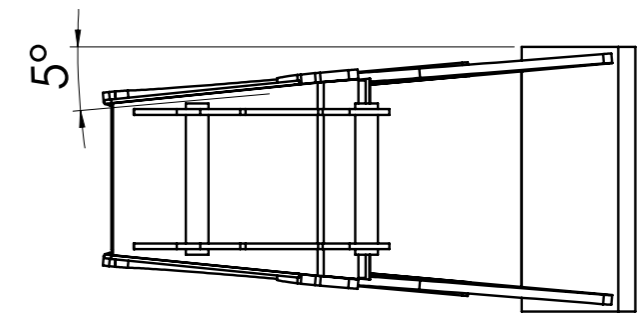
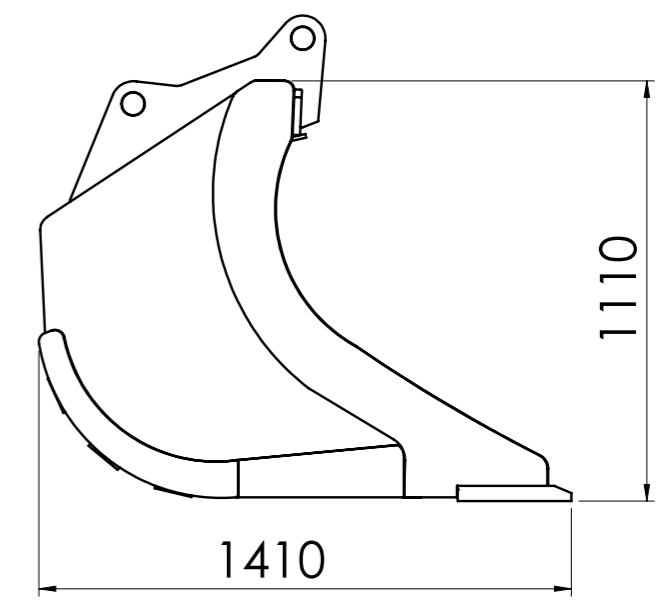
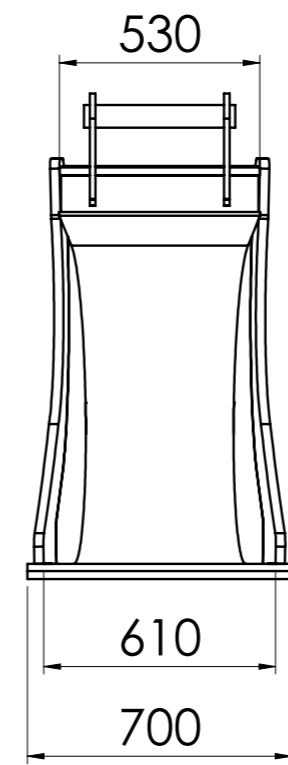

4	Bottom bar	HB 500	20x100 mm
3	Side member	HB 400	25 mm
2	Bottom plate	S355	10 mm
1	Front edge	HB 500	40x300x700 mm
NO.	TITLE	MATERIAL	DESCRIPTION

	Volume	400 L	Mass	520 kg	Scale

Drawn	Teet Toming	Name
Checked		
Approved		
		CAB-826

	Sheet	Date
	1 of 1	30.03.2016